

**Automatic Roll Paper Towel Dispenser & Waste Receptacle - 110-240V AC – Surface Mounted**

Paper Towel Combination Units

Traditional

MasterFormat Section 10 28 13

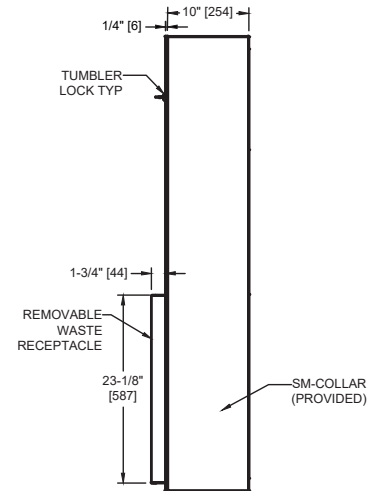
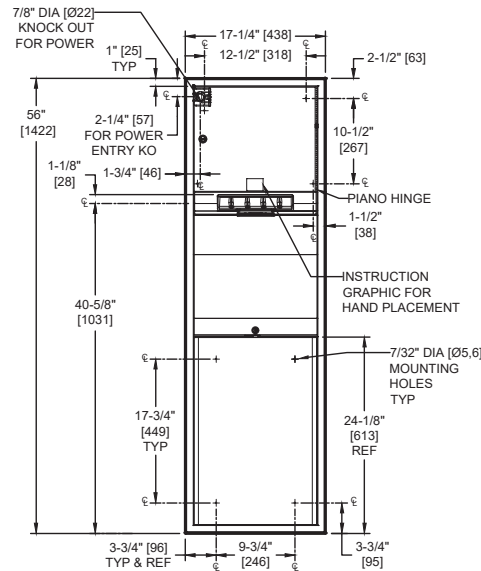

Scan for Information



**SUSTAINABILITY/LEED**

MR 4.1 (1) MR 6 (1) EQ 4.2 (1)  
MR 4.2 (1) EQ 4.1 (1) EQ 4.4 (1)

**NOTE:**  
ALL DIM'S INCH [MM]  
ILLUSTRATION FOR REF ONLY AND NTS  
FOR CLEANING INSTRUCTIONS SEE APPROPRIATE SECTIONS IN  
PRODUCT CARE & MAINTENANCE BULLETIN (PCM) ON ASI WEBSITE

**PRODUCT OVERVIEW**

Proximity sensing no-touch unit dispenses a pre-set length per cycle from 8" [205] or 9" [230] wide standard towel roll up to 800 ft. (244m) long and has stub roll capability for continuous dispensing. 12 gal. (45.4 liters) disposal capacity. Surface mounted with stainless steel collar. Powered by internal low-voltage adapter (supplied) using 110-240VAC, 50/60 Hz and providing output of 5VDC @ 1A.

**KEY FEATURES & SPECIFICATIONS**

- "Touch Free" dispensing for better hygiene
- Double-pan construction door has "no-Flex" fiberboard filler for added rigidity and strength
- Type 304 Stainless Steel - Satin Finish
- Door is attached to the cabinet with a 3/16" Dia. [Ø5]. Heavy-duty, Multi-Stacked Stainless Steel Piano Hinge
- Surface Mounted - w/ -9 collar
- Automatic - AC - 110 - 240V - "No Touch"
- RollTowels - up to 800 ft. [244M] Length / 13.3 Gal. (50.4 L) Waste Capacity

**OPERATION & MAINTENANCE**

Towels are dispensed one at a time automatically when hands are placed in sensor zone until supply is depleted. Unit may be reloaded with a full roll to automatically start when finished with an existing partial roll. Locking door and waste container prevents unauthorized access and removal. Waste container is emptied manually on cycle determined by maintenance needs.

**TECHNICAL INFORMATION / PRODUCT PROPERTIES**

Property	Value
Dimensions	17-1/4" [438] W x 56" [1422] H x 11-3/4" [298] D
Construction	Type 304 Stainless Steel - Satin Finish Door is attached to the cabinet with a 3/16" Dia. [Ø5]. Heavy-duty, Multi-Staked Stainless Steel Piano Hinge
Power	110-240V AC
Operation	Automatic "No-Touch"
Mounting	Surface Mounted - w/ 9" Collar
Capacity	Roll Towels - up to 800 ft. Length / 13.3 Gal. (50.4 L) Waste Capacity

**INSTALLATION**

Unit is mounted on wall using #10 self-threading screws (by others) through concealed mounting holes provided. For compliance with 2010 ADA Accessibility Standards install unit so that bottom edge of towel dispenser door is 48" [1219] maximum Above Finished Floor (AFF). Power is supplied by code approved cable or conduit (by others) to back of unit at location indicated on diagram and terminated in utility simplex outlet box (provided) inside cabinet. Power required is 110-240VAC at 50/60 Hz protected by a 15A circuit breaker (by others) for low voltage adapter that draws ¼ Amp. Power adapter for dispenser unit is supplied cabled and plugged into dispenser and is plugged into simplex outlet (by others).

**WARRANTY**

One (1) Year from date of Invoice