

NB: all dimension inch(mm)

Dispenser Mounting Hole Drilling Template

(Scale 1:1)

Opposite Side Fig. 2B.

7. Refill Soap Supply:

(Fig. 12).

1. Ensure soap is free of particles (**Viscosity 1.5-10 cP (mPa·s)**).
2. Ensure filling cup and funnel are clean.
3. Max filling level as shown in Fig. 12.
4. Soap tank will clip-on from bottom up. **Avoid Kinking Dip-tube.**
5. Push counter reset button (must reset after every refill).
6. Press PUSH to release soap tank for refilling.
7. Clean soap tank with water periodically.
8. When low soap level indicator is turned off (see Fig. 14), remember to check regularly and refill soap when level is approximately 3/4"(20) from bottom.

8. Operation:

1. Start the system by passing your hand under the spout. Soap will dispense automatically within 1 second. (Fig. 13) (Dispense 10-20 times for first time use to prime dip-tube).
2. Refill soap when soap level is low. (Fig. 12).
3. Low soap LED condition indicator can be turned ON or OFF (see Fig. 14). Factory setting is preset to ON.
4. End of each dispense cycle has momentary draw back of approx 500 ms to prevent last drop of foam from becoming hanging drip.
5. When dispenser is idle for a period of 24 hrs \pm 1 hr from last dispense cycle, a dispense cycle will be initiated automatically to help prevent clogs in the nozzle. This will also help keep supply prime ready for next user to have immediate use.

9. Maintenance:

1. Use soft and moist cloth to clean. Avoid spraying water directly at the system.
2. Clean sensor cover with care. Avoid scratching the cover.
3. Replace batteries every year on anniversary of installation or sooner if high use requires.
4. During power connection, red LED light will flash four times to indicate system reset/ready.

Fig. 12

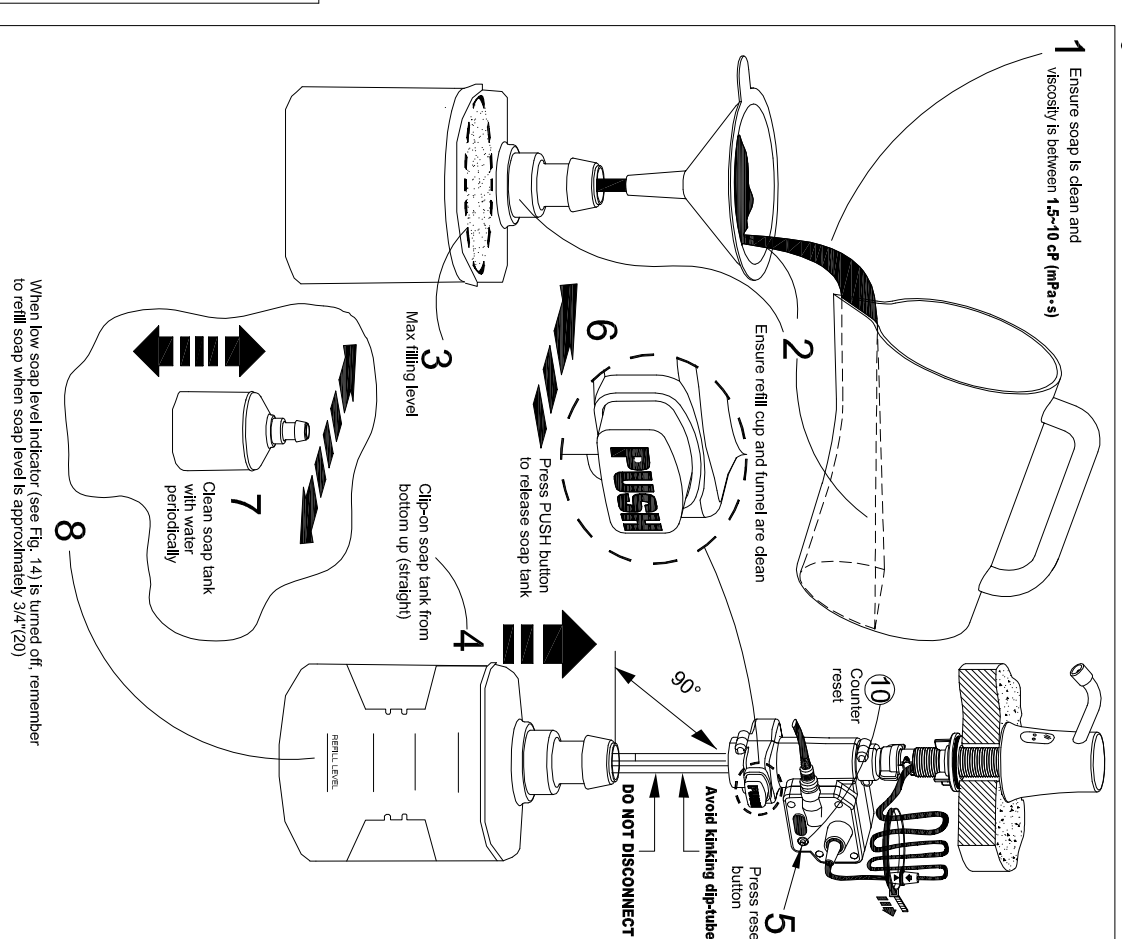

Fig. 13

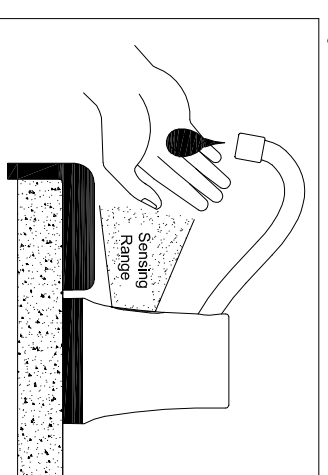

Fig. 10

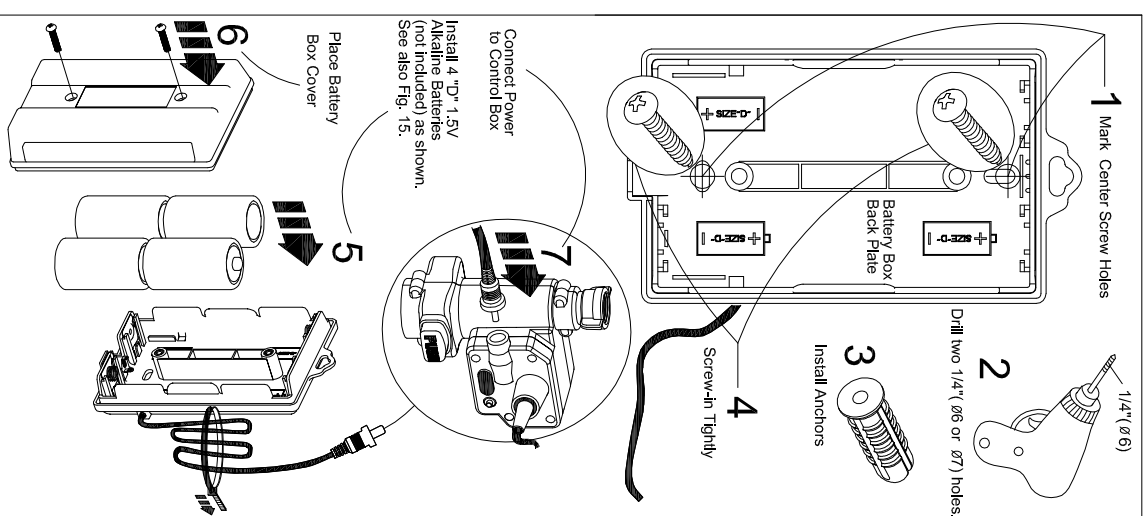
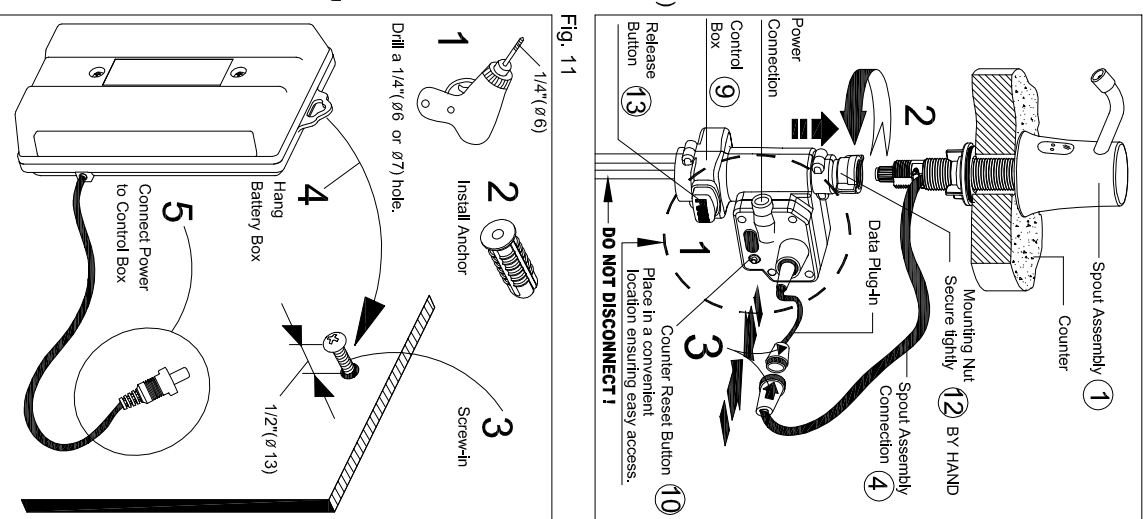

Fig. 9 Ref Section 5. Circle items ref Section 1.



10. Troubleshooting:

Problem	Diagnosis & Solutions
Red LED not working	<ul style="list-style-type: none"> • Check if batteries are properly installed. • Change batteries if power is depleted. • Sensor cover is blocked or dirty. Please clean sensor cover with care.
Red LED solid on	<ul style="list-style-type: none"> • Batteries low. • Replace batteries.
Red LED flashing	<ul style="list-style-type: none"> • Sensor is detecting an object. Remove any object that is causing false activation. • System malfunction; please consult with distributor.
Blue LED flashing	<ul style="list-style-type: none"> • Low Soap Level. • Press counter reset button 10. • Refill Soap. • System malfunction; please consult with distributor.
Low dispensing volume	<ul style="list-style-type: none"> • Verify soap viscosity is in range. • System malfunction; please consult with distributor. • Ensure no kink in dip tube.
Not dispensing	<ul style="list-style-type: none"> • Reinstall all cables. • Ensure battery voltage is above 5.4 V. • System malfunction; please consult with distributor. • Low soap level - Refill.
Problem not described above	<ul style="list-style-type: none"> • Please consult distributor.

Fig. 14

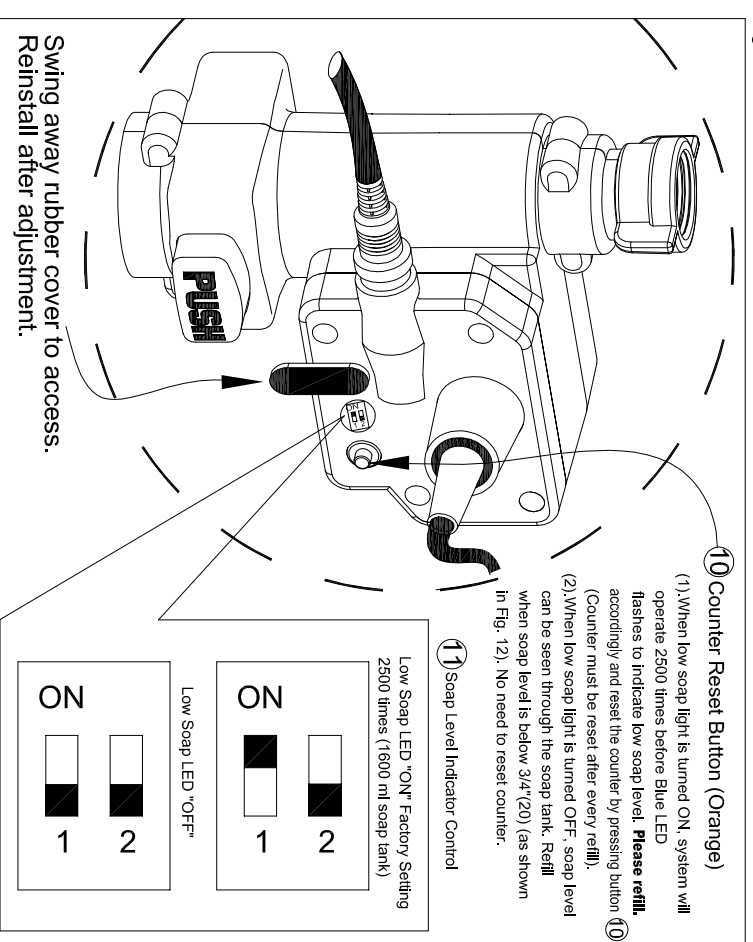

5. Control Box Installation:

- 5.1. Installation procedure (Fig. 9).
- 5.1.1. Ensure areas around soap tank release button 13, counter reset button 10 and control box to spout cable connection 4 are clear for operation.
- 5.1.2. Confirm position of control box, push up to engage shank spline then turn mounting nut as shown by hand to tighten housing onto spout shank.
- 5.1.3. Observe alignment arrows on plug & socket of spout cable connection 1 and push together to mate connectors. Ensure complete engagement of pins.
- 5.1.4. Use one Ty-Wrap 19 to bundle and retain loose excess cable out of the way of any plumbing and away from the control box switches to protect plug connection.

6. Battery Box Installation:

- 6-1. Observe polarity indication for correct operation (Fig. 15). Ensure that batteries are installed in proper orientation to provide uniform polarity power.

6.2. Permanent Wall Mounting (Fig. 10)

- 6.2.1. Use back plate as template to mark holes locations.
- 6.2.2. Drill two (2) holes at location marks:
 - 6.2.2.1. For dry wall or masonry mounting make 1/4" - 9/32" diameter (Ø6 - Ø7)
 - 6.2.2.2. Install plastic anchors 7 flush with wall surface.
- 6.2.3. For solid wood mounting make pilot holes 3/32" diameter (Ø2.4).
- 6.2.3. Install two (2) screws 7 through holes in back plate and tighten in place.
- 6.2.4. Install four (4) "D" size 1.5 V alkaline batteries in correct polarity (Fig. 15).
- 6.2.5. Place battery box cover and install retaining screws.

6.2.6. Connect power cable 9 plug to control box power connection socket.

- 6.2.7. Use one Ty-Wrap 19 to bundle and retain loose excess cable out of the way of any plumbing and away from the control box switches to protect plug connection.

6.3. Removable Wall Mounting (Fig. 11)

- 6.3.1. Use back plate as template to mark hole location.
- 6.3.2. Drill one (1) hole at location mark:
 - 6.3.2.1. For dry wall or masonry mounting make 1/4" - 9/32" diameter (Ø6 - Ø7).
 - 6.3.2.2. Install plastic anchor 7 flush with wall surface.
- 6.3.2.3. For solid wood mounting make pilot hole 3/32" diameter (Ø2.4).
- 6.3.3. Install one (1) screw 7 in hole and leave protruding approx 1/2" (13).
- 6.3.4. Hang battery box back plate on screw.
- 6.3.5. Follow steps 6.2.4 through 6.2.7 above.

Fig. 15

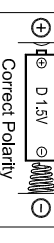

ASI MODEL NO 20334 Automatic Deck Mount Foam Soap Dispenser

Owner's Manual & Installation Guide with Template

1. Assembly and Packaging List Ref

Item	Description	Qty
1	Spout Assembly	
2	Low Voltage LED Light (Red)	1
3	Low Soap LED Light (Blue)	
4	Spout Assembly Connection	
5	Wrench for tightening Item 7 Basin Nut	1
6	Rubber Gasket	2
7	Basin Nut	1
8	Spacer (add 3/8" (10) height) Optional	1
9	Control Box W / Dip Tube	
10	Soap Counter Reset Button (Orange)	
11	Counter Adjustment Switches 2500 times (1600 ml tank) Low Soap LED Disable/Enable (See detail Fig. 14)	1
12	Control Box Mounting Nut	
13	Soap Tank Release Button	
14	Battery Box	1
15	Battery Box Connection Cable	
16	Soap Tank, Refillable	1
17	Screws & Anchors Kit M4x19; Ø 7 Hole	2 sets
18	Alkaline Batteries Required D 1.5V PC1300 Duracell (Not Included)	4
19	Ty-Wraps	2

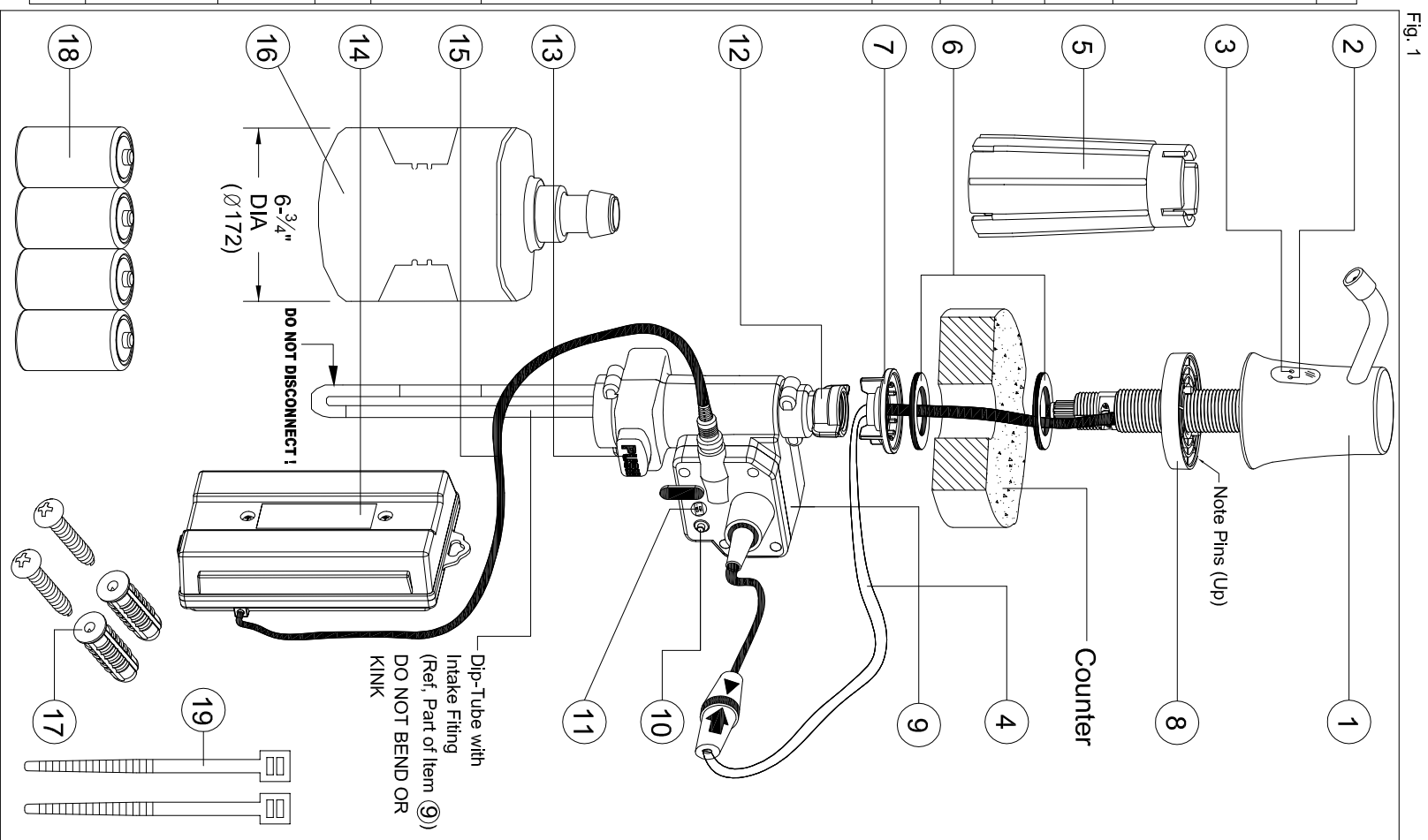

Fig. 1

2. Specifications:

Bottle Capacity	1600 ml (54 oz)
Battery Type DC 6V	4 x D 1.5V Alkaline Batteries
Sensing Range	Auto Adjustment
Operating Temp	4°C-40°C (39°F-104°F)
Activation Time	0.5 ~ 1 sec
Soap Volume	0.03 oz (0.8ml)
Viscosity	1.5~10 cP(mPa·s)
pH	7 ± 1.5

Fig. 2B (Counter drilling template)

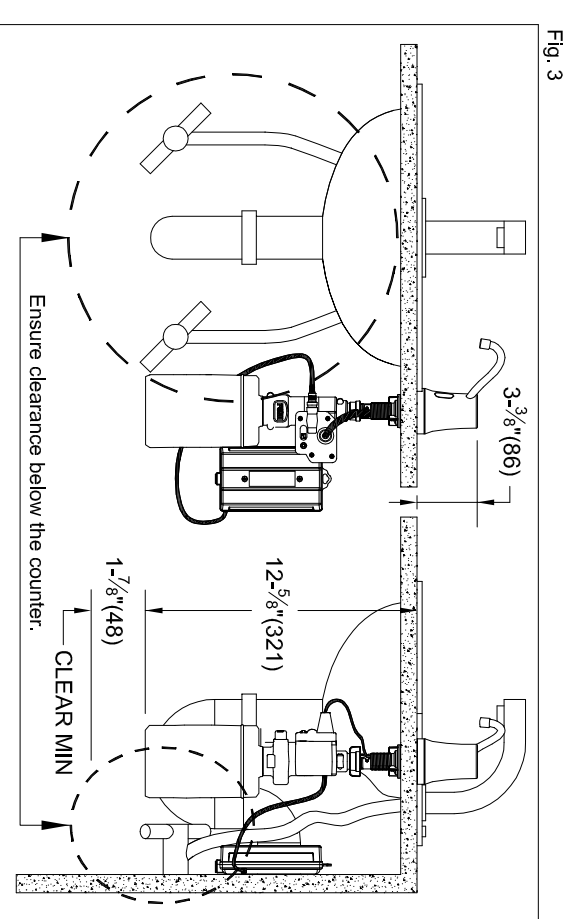
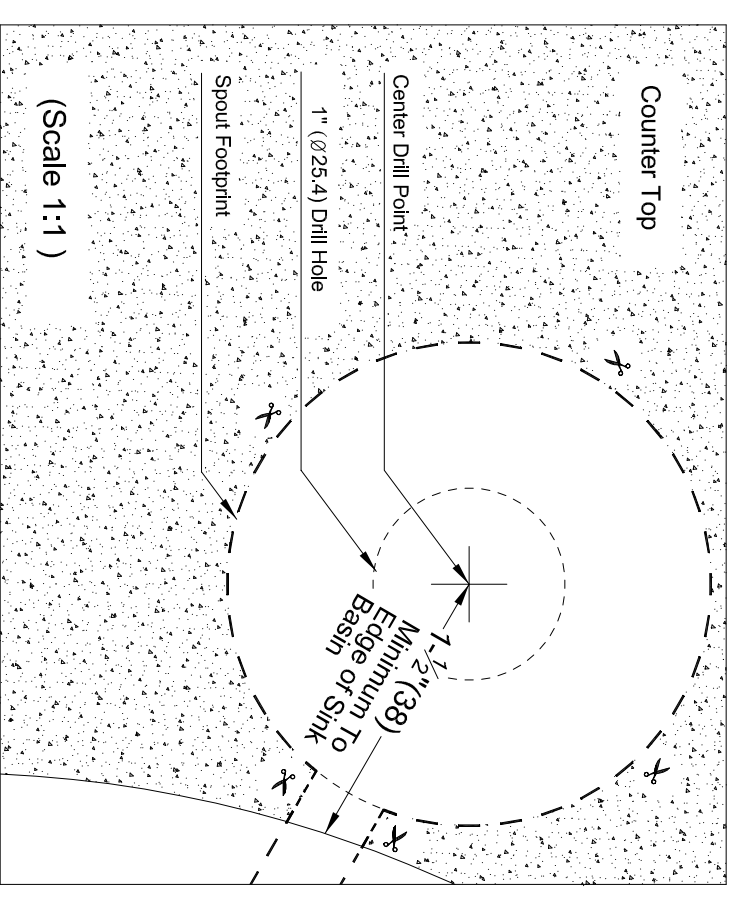

Fig. 3

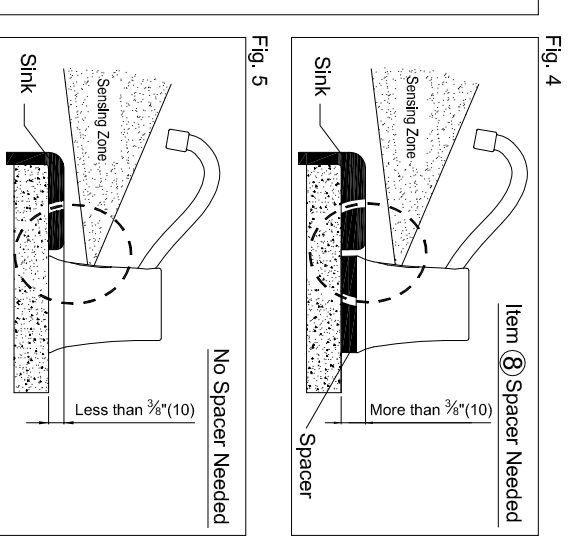

Fig. 4

- ### 4. Spout Installation:
- #### 4-1. Do You Need Spacer? (Fig. 7).
1. Add spacer, engage pins & grooves.
 2. Place first rubber gasket.
 3. Place spout shank into counter hole.
 4. Place second rubber gasket.
 5. Place basin nut.
 6. Adjust spout angle (Fig. 6) then tighten by hand with wrench provided ⑤.

Fig. 7

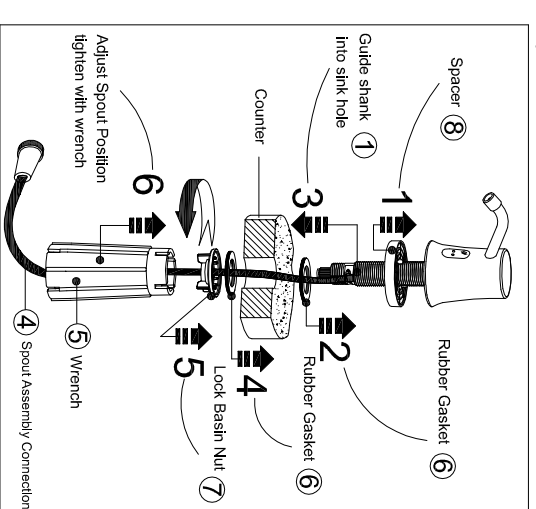
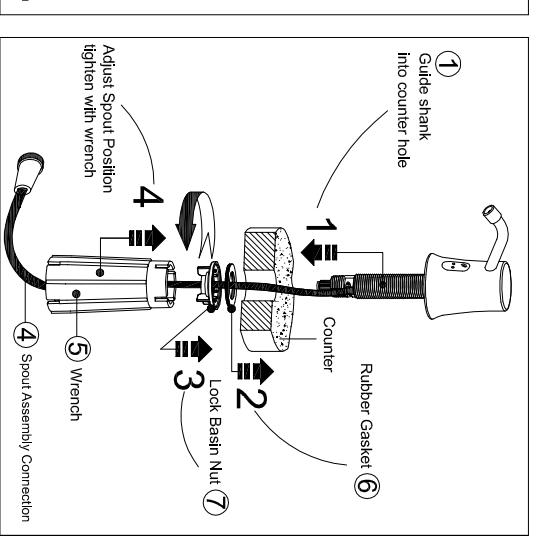

Fig. 8



3. Installation

3-1. Replacing Existing Dispenser.

- Remove old components.
- Clean area.
- Check if hole is large enough.
- Check if small, enlarge to 1" Dia (Ø25.4) C-2. If larger than 1-3/4" Dia (Ø44.5) provide reducer bushing (not included)
- Proceed to 3-3.

3-2. New Dispenser Installation.

- Choose a suitable location (Fig. 2A), cut and paste installation template (Fig. 2B) on the drilling location. (Ensure clearance above and below the counter as shown in Fig. 3).
- Drill a 1" (25.4) diameter hole in counter top. C. Clean area around hole.

3-3. Determine whether adding a spacer is needed (Paragraph 4).

- Add spacer if sink rim is 3/8" (10) higher than the counter (Fig. 4).
- No need to add spacer if sink is within 3/8" (10) above the counter (Fig. 5)

NB: all dimension inch(mm)

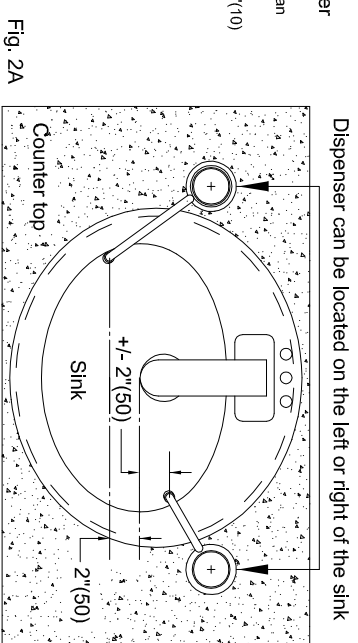

Fig. 2A