

Royal™ Automatic Foam Soap Dispenser

Soap Dispensers

Royal

MasterFormat Section 10 28 13

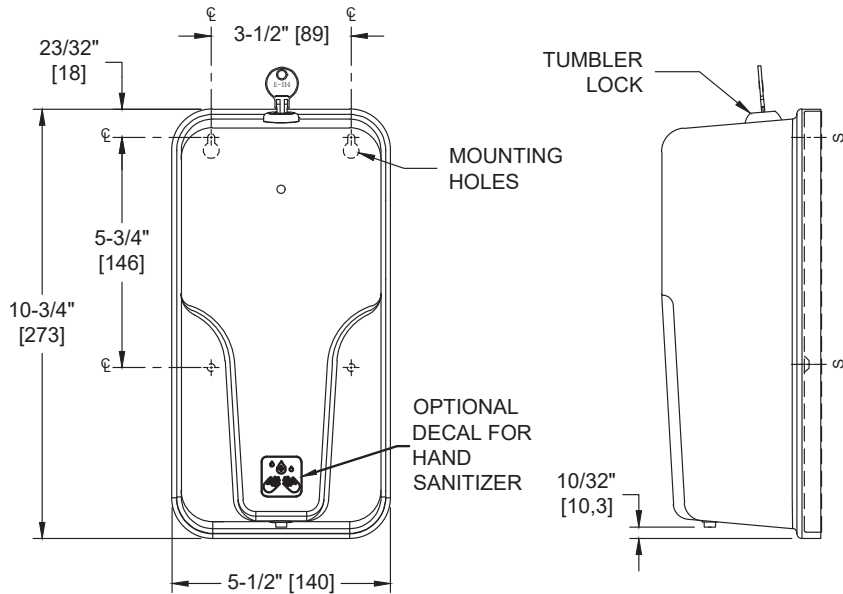

SUSTAINABILITY/LEED

MR 4.1 (1) MR 6 (1) EQ 4.2 (1)
MR 4.2 (1) EQ 4.1 (1) EQ 4.4 (1)

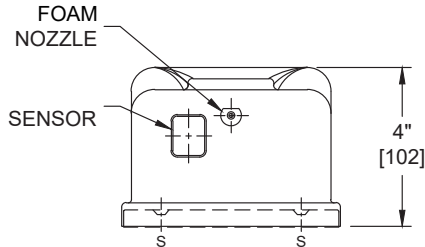

NOTE:
ALL DIM'S INCH [MM]
ILLUSTRATION FOR REF ONLY AND NTS
SEE SOAP DISPENSER CARE & MAINTENANCE
DOCUMENT ONLINE FOR CLEANING

PRODUCT OVERVIEW

A foam drop is dispensed out of the nozzle on unit bottom each time its sensor is activated. Powered by 4 AA-size batteries (not included). Capacity: 33.8 oz. (1000 ml) of liquid foaming soaps within a wide range of viscosity. Soap Requirements: Proper usage of this dispenser requires, that only soap within the following range for viscosity and pH may be used. Viscosity Range (mPa•s or cP): 1 – 50. pH Range: 5.5 ~ 8.5.

KEY FEATURES & SPECIFICATIONS

- "Touch Free" Dual Dispenser - Foam Hand Sanitizer or Foam Soap
- Seamless drawn construction
- Type 304 Stainless Steel - Satin Finish
- Gently Radiused Edges creates a modern look
- Surface Mounted
- Automatic - Battery Operated - "No Touch"
- 33 oz. (1.0 L) Capacity

OPERATION & MAINTENANCE

Unit shall operate each time an object is positioned within the sensing distance of 3-1/8" [80] ± 3/8" [10] from unit bottom. A foam mass of 1-4 oz to 1/3 oz [7 ml ~ 9 ml] or similar volume of foaming hand sanitizer will be pumped out of the nozzle on unit bottom for each activation while batteries are at suitable charge level (LED is not flashing) and correct viscosity liquid foaming soap or foaming sanitizer is present in the tank. Door has lock to provide security and vandal resistance after each foaming soap or foaming sanitizer refill and battery change service interval. Make sure to wash out tank & pump completely if changing from foaming sanitizer to foaming soap or vice versa.

TECHNICAL INFORMATION / PRODUCT PROPERTIES

Property	Value
Dimensions	5-1/2" x 10-3/4" x 4" [140 x 273 x 102]
Construction	Type 304 Stainless Steel - Satin Finish. Gently Radiused Edges create a modern look
Mounting	Surface Mounted
Options	N/A

INSTALLATION

Secure concealed base plate to wall with four (4) self-threading screws (supplied by others: two (2) #8 x 3/4" [M4.5x20] pan head & two (2) #8 x 3/4" [M4.5x20] flat head through mounting holes provided in plate into plastic wall anchors (by others) or other suitable mounting system (by others). Alternatively, unit may be installed on stand (Model #FS-0300) with mounting hardware supplied with stand. Install four (4) AA size 1.5 V cells (supplied by others) in concealed battery compartment according to polarity indication and snap-latch battery door. Fill tank with appropriate viscosity soap or sanitizer to correct level and lock door. Locking door activates concealed button to initiate operation. Retain key provided for future access. See OM for complete set up and operation instructions.

WARRANTY

One (1) Year from date of invoice