

**BABY CHANGING STATION, VERTICAL – STAINLESS STEEL, SURFACE MOUNTED**

Baby Changing Stations

MasterFormat Section 10 28 13

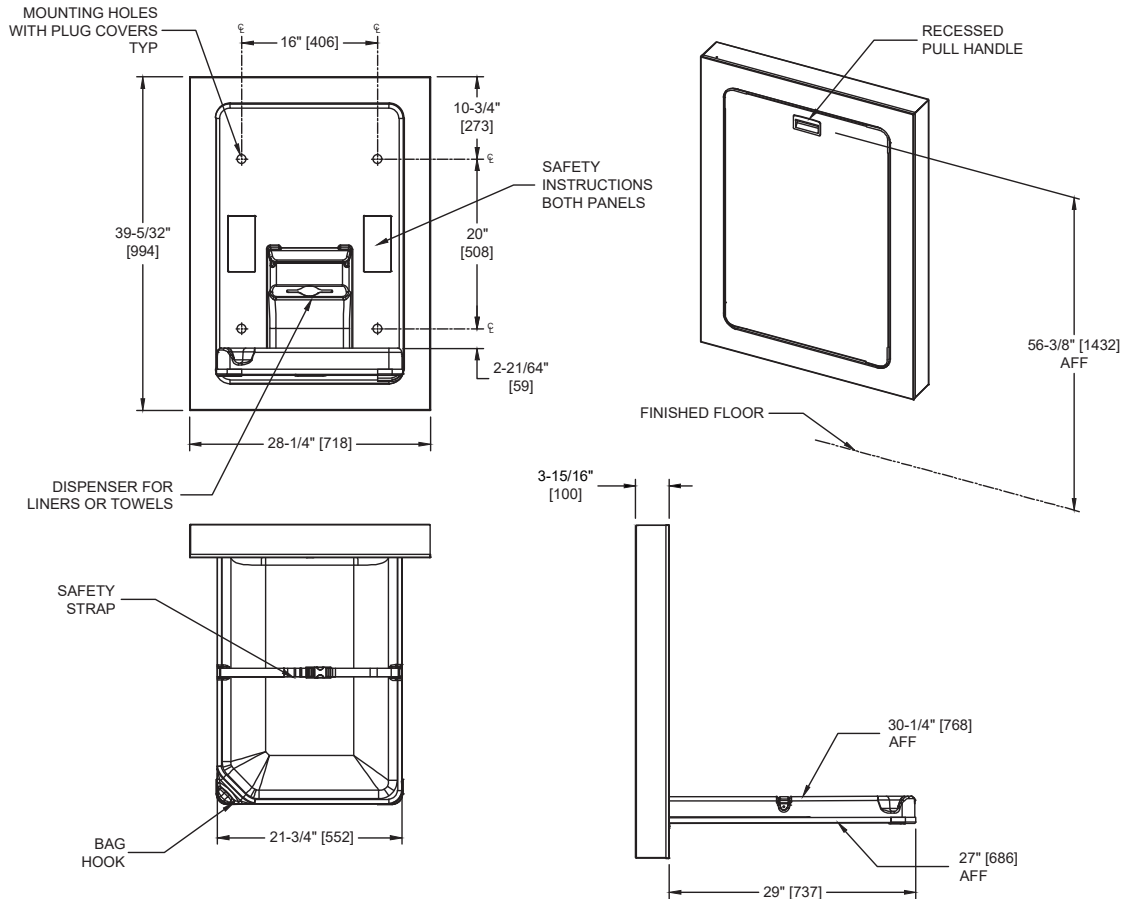

Scan for Information



**SUSTAINABILITY/LEED**

MR 4.1 (1) MR 6 (1) EQ 4.2 (1)  
 MR 4.2 (1) EQ 4.1 (1) EQ 4.4 (1)

**NOTE:**  
 ALL DIM'S INCH [MM]  
 ILLUSTRATION FOR REF ONLY AND NTS

**PRODUCT OVERVIEW**

This vertical station has a door facing and collar made from 20 gauge 304 stainless steel. Fabricated of FDA-approved fungus and bacteria-resistant plastic. Unit supports a static load of 300 lbs. (136 kg). Surface mounted with stainless steel collar. Unit platform is shaped to keep a child restrained from rolling out of the bed. Unit is easily opened and closed by user with one hand in any location and handle cavity is provided on door face for preferred use. Unit is operable with less than 5lb of force (22.2N) while not requiring any tight grasping, pinching or twisting of the wrist. Bed liner/towel dispenser presents liners or towels for user hygiene and convenience. Dispenser lid is provided for sanitary protection and ease of loading of wipes or liners. Safety strap is easily adjustable by user for baby size and Sure-Lock latch securely resists opening until released by opposing finger pressure by adult caretaker/parent. Liners/towels are easily replenished by service personnel as required.

**KEY FEATURES & SPECIFICATIONS**

- Vertical space-saver changing station is ideal for mounting in smaller spaces. Damped gas springs make one handed operation easy, using less than 5lbs force (22.2N) - no tight grasping, pinching or twisting of the wrist.
- Includes one integral bag hook and bed-liner dispenser (convertible to a multi-fold towel dispenser)
- Door facing and flange dress trim are made of 20 gauge Type 304 Stainless Steel - Satin Finish.
- Changing Surface is fabricated of FDA-approved fungus and bacteria-resistant HDPE.
- Surface Mounted with stainless steel collar. Designed to support a static load of 300 lbs (136.1 kg) and be tested in excess of 350 lbs (158.8 kg)
- The bed is designed to cradle a child's body. An adjustable two-part, vinyl-coated safety strap with a Sure-Lock latch aid in safety.

**OPERATION & MAINTENANCE**

Unit platform is shaped to keep a child restrained from rolling out of the bed. Unit is easily opened and closed by user with one hand in any location and handle cavity is provided on door face for preferred use. Unit is operable with less than 5 lbs (22.2N) while not requiring any tight grasping, pinching or twisting of the wrist. Bed liner/towel dispenser presents liners or towels for user hygiene and convenience. Dispenser lid is provided for sanitary protection and ease of loading of wipes or liners. Safety strap is easily adjustable by user for baby size and Sure-Lock latch securely resists opening until released by opposing finger pressure by adult caretaker/parent. Liners/towels are easily replenished by service personnel as required.

**TECHNICAL INFORMATION / PRODUCT PROPERTIES**

Property	Value
Dimensions	Closed: 28-1/4" x 39-5/32" x 3-5/16" [718 x 995 x 100] Open: 28-1/4" x 39-5/32" x 32-3/8" [718 x 995 x 822]
Construction	Type 304 Stainless Steel - Satin Finish FDA-approved fungus and bacteria-resistant plastic bed
Mounting	Surface Mounted
Capacity	Supports a static load of 300 lbs. (136 kg)

**INSTALLATION**

Installation instructions along with operation and maintenance manual are provided with each unit. Surface mount unit using hardware supplied through recessed mounting holes. Hardware kit supplied has fasteners suitable for metal or wood stud walls in dry locations and general hollow wall construction where adequate substrate strength is obtained. Fasteners and anchors for masonry walls are not provided. Wall reinforcement must be suitable to sustain transfer of maximum unit loading. Mounting hole plug covers are supplied to conceal fasteners after installation. Follow procedure in instructions provided and as summarized here:

1. Locate wall studs at 16" [406] OC for fastening the station. If two (2) wall studs cannot be used, use two (2) screws into ONE stud and drill pilot holes and install toggle fasteners securely in the wall at non-stud location.
2. Attach unit to wall studs with four (4) 1/4" x 3" long Phillips pan head self-threading screws through flat washers.
3. Where wall studs are not available attach with four (4) 1/4" - 20 x 3" pan head bolts with flat washers into toggles or expansion nuts.

**WARRANTY**

Five (5) Years from date of invoice